



# Signal Fire AI-10A Optical Fiber Fusion Splicer User Manual

[Home](#) » [SIGNAL FIRE](#) » Signal Fire AI-10A Optical Fiber Fusion Splicer User Manual 

Signal Fire AI-10A Optical Fiber Fusion Splicer User Manual



## Contents

- 1 Chapter III Arc Calibration
- 2 Chapter IV Replace Electrode
- 3 Chapter V Cutting and Releasing Fibers
- 4 CHAPTER VI Fiber Stripping And Put Into Holder
- 5 Chapter VII Activate Electrode
- 6 Chapter VIII Replacing Blades
- 7 Chapter IX OPM and Optical Modules
- 8 OPM and Optical Modules
- 9 Chapter X Welcome Interface
- 10 Chapter XI Intelligent Management
- 11 Documents / Resources
  - 11.1 References

## Chapter III Arc Calibration

ARC Calibration: According to the local ground elevation, temperature, moderate and other environmental factors to match the most suitable discharge ARC, in order to obtain the best splicing effect, we strongly recommend you to do arc calibration when it is the first time to use the new machine, the seasonal changes, the use place changes, or you replaced the electrodes: discharge correction should be done after changing the type of fiber (such as single mode and multi-mode switching)

**The procedure for ARC Calibration is as follows:**

1. log into your account;

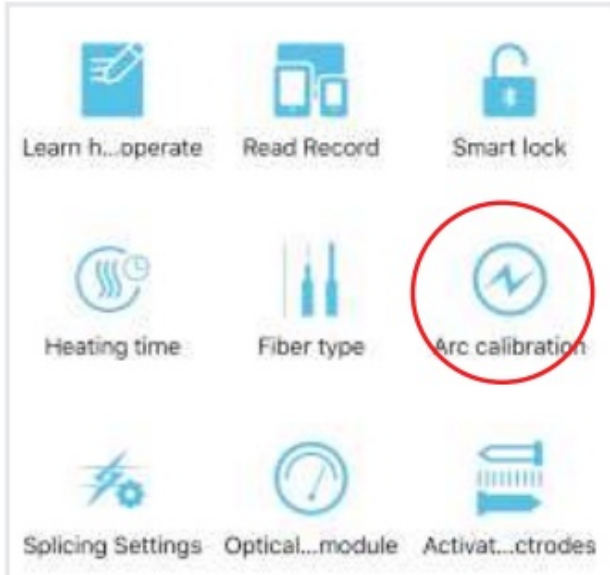

2. connect the machine to APP:
3. press the “arc calibration” button

Machine fusion page on the left side, there is a normal work status icon will change into the arc calibration status icon. And then you can put the cleaved fiber on the machine, and close the wind cover, wait the machine automatic to process the arc calibration.



If the icon still the icon of the arc calibration, but the fiber icon is flickering, we need to take the fiber out of the machine. then cleave a new fiber again and put it on the machine and wait the machine process. loop above operation until the icon change from arc calibration icon into normal working icon which means the arc calibration succeed.

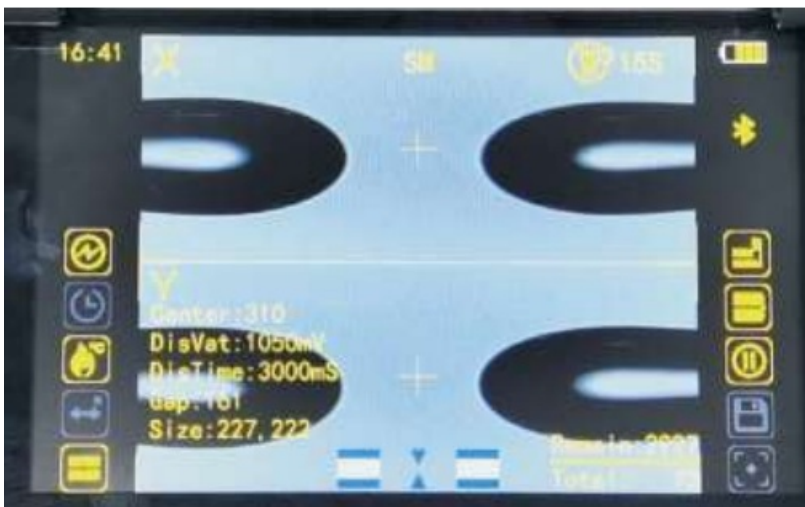

## ChapterIV Replace Electrode

Electrode replacement must use the genuine original electrode designed for this machine from factory. When the number of electrode is used close to 3000 times, the machine will remind you to replace it. When it reaches to 3000 times, it is necessary to replace the electrode and activate it then you can use again(see page 29 **ACTIVATE ELECTRODE**). Otherwise it may affect the splicing quality, or even shut down the program automatically, and could not splice.

**The electrode replacement procedure is as follows:**

1. Please pinch the electrode over on both sides slightly, see the location in picture then remove up the electrode cover.



2. The cap size of two electrodes is different, wider head is for the electrode which is close to screen direction



3. Take away the cover as shown in picture.



4. Use the screwdrivers to loosen the screws

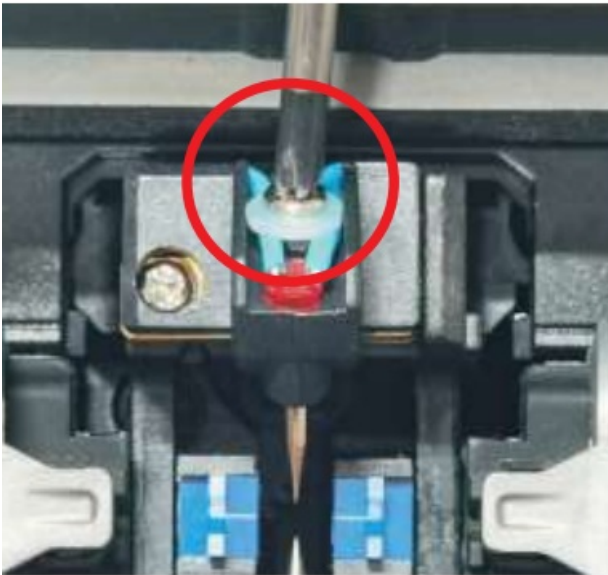

5. Use tweezers to remove the lights



6. Loosen the screws of the electrode base, and take the screws out



7. Push the copper gasket out of the hole, then take the electrode and the copper gasket out of the machine,



8. After removed the electrode. base's status



9. Replace the new electrode and put the copper gasket back to slot please note that keep the copper gasket's wide gaps towards to the tips side.



10. When mount the electrode, push the copper gasket pins to the hole.

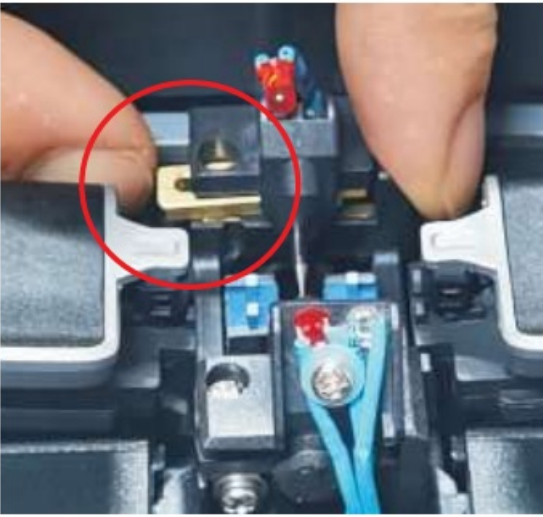

11. Check the screws' hole and then tighten the screws. and put the red lights back to the light's hole(no need mount the screws of the lights)

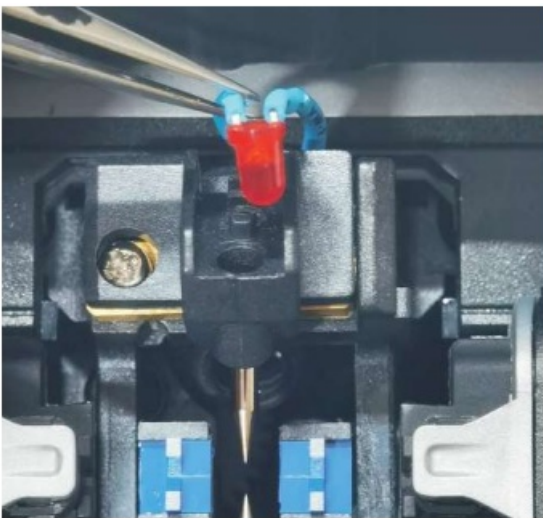

12. Put the electrode cover back then the electrode change has been done



## Chapter V Cutting and Releasing Fibers



Cleaning button (including manual cutting) When there are broken fibers or foreign objects on the clamping surface that affect the cutting quality or even prevent normal cutting, it is necessary to briefly press the cleaning button. After the clamping surface is retracted and the spacing between the clamping surfaces is increased, a brush or cotton swab can be dipped in alcohol to clean. After cleaning, briefly press the cleaning button again to reset the clamping block and enter normal working mode. If closed through the "SignalFire2 software

After a malfunction occurs in automatic cutting or automatic cutting, press and hold the cleaning button for 1.5 seconds, and the cutting knife will perform a single cut.

**Note** if cutting fails for 3 consecutive times the screen will prompt to clean the clamping surface of the cutting blade. After cleaning is completed, press the cutting button again to exit the cleaning mode.

**Reminder:** The shortest fiber length must be greater than the clamping surface to ensure stable fiber clamping.

When there are residual optical fibers or impurities on the clamping surface that affect the cutting quality, removing the brush to clean the clamping surface can ensure the cutting quality.

#### **Schematic diagram of cutting knife fiber release**

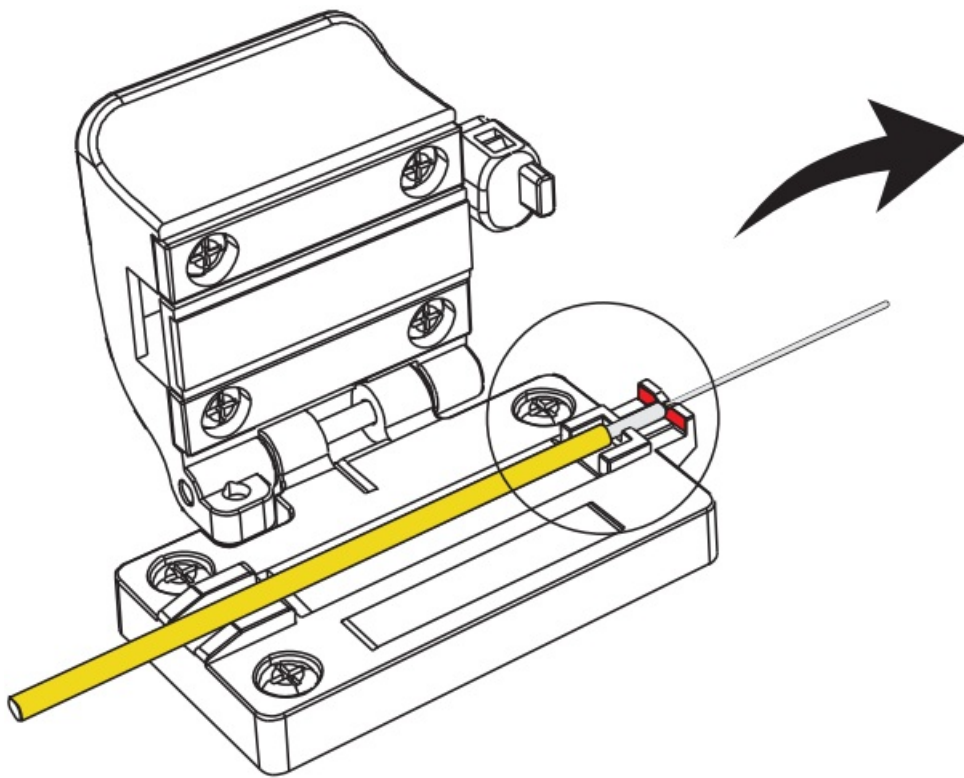

**Jumper**

Place the yellow cladding into the L-shaped limit groove, and the white cortex must be close to the red area stop block.

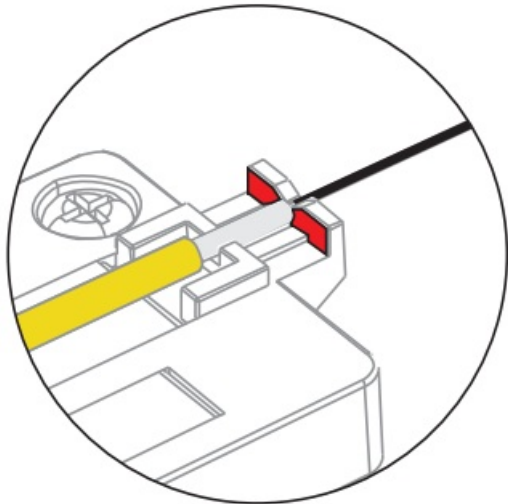

**Leather Fiber**

Inside the L shaped limit groove of the leather fiber outer layer

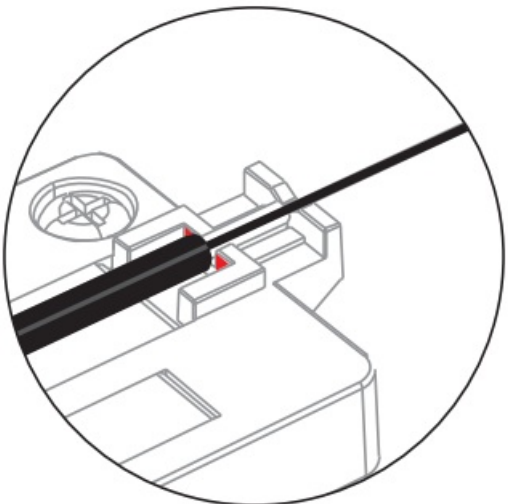

**Bare fiber**

Bare fibers can be placed as needed without the need for limit placement

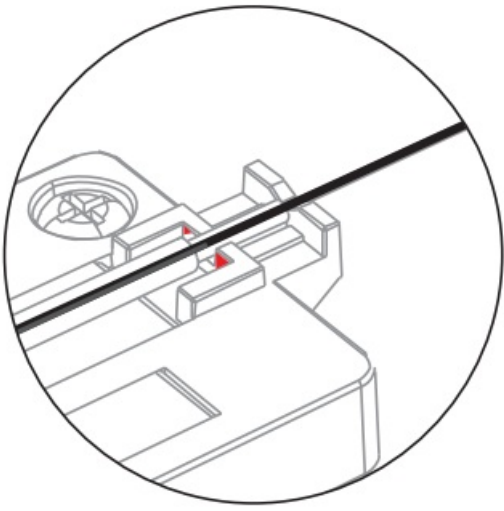

## CHAPTER VI Fiber Stripping And Put Into Holder

Instructions for put fiber into holder:

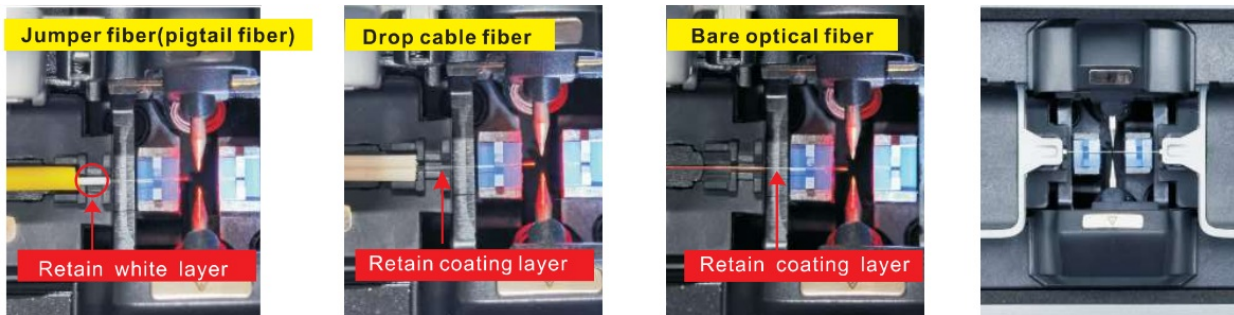

**Note:**

1. When releasing the fiber, pay attention to placing the fiber in the blue V-shaped groove. The top of the fiber should be close to the needle tip of the electrode. If it is too far from the electrode needle tip, it will prompt to re-release the fiber
2. The top of the optical fiber should not exceed the tip of the electrode needle

## Chapter VII Activate Electrode

**PS.** The electrodes on the new machine doesn't need to activate because we have activated before ex-factory. Only when the electrodes life on the machine is expired(after you used out 3000 times) then you need to replace the electrode and activate it, you need to replace the electrode and activate it. Attention when the machine didn't remind you to replace the electrode(used times is low than 2800), then you don't need to change the electrode. Remember buy our brand electrode which has the anti-counterfeiting QR code on the cover.

**ATTENTION:** after you have replace the electrode and activate the machine, please remember to do an arc calibration so that the machine can performance better.



1. log into your account;
2. Use APP to connect to the machine
3. press the button “Activate Electrode”, then get into the page of the electrode activation



1. Scan the QR Code which is on the electrode. cover, or you can input the QR Code Number into the text box.
2. After the number is show in the text box, then we press the button “verification code” to activate the machine.

After you have done the verify the code, then it may load for few seconds, then it will remind you “Activation Succeed”. then the machine can normal use again.

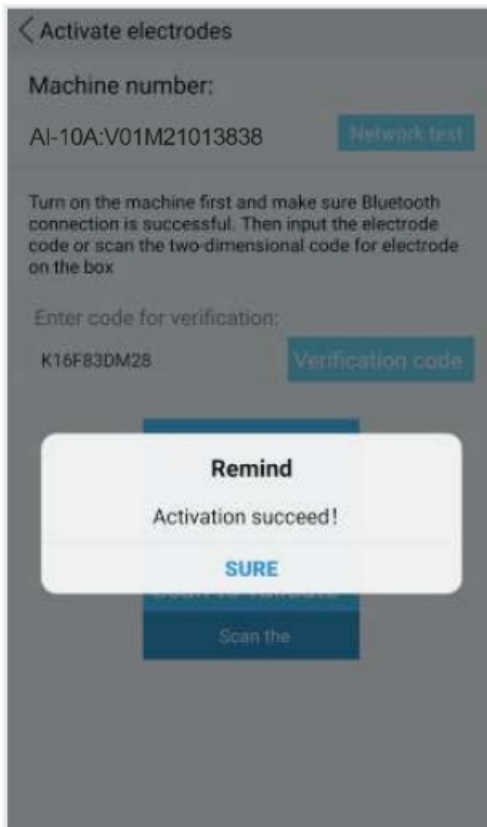

## Chapter VIII Replacing Blades

When the cutting quality decreases to the point where it cannot meet the cutting requirements, please replace the blade in a timely manner. Replacing the cutting blade must use a legitimate original blade designed specifically for this machine, otherwise it may affect installation and cannot guarantee cutting quality.

**The steps for blade replacement are as follows:**

1. Use a Phillips screwdriver to remove the four screws at the red



2. Use a flat screwdriver to gently tilt the screen cover as shown in the figure, and then remove the screen cover



3. Place the screen cover on the side of the body, no need to remove the connecting wire



### Replacing Blades

4. Put on cotton gloves and pinch the blade tightly with your hand to avoid hurting your hand, then use a screwdriver to remove the blade



5. Install a new blade and tighten the screws



6. Replace the screen cover and secure the four screws shown in the figure. Blades change completed



## Chapter IX OPM and Optical Modules

Effectively measure connection loss, verify continuity, and assist in evaluating the transmission quality of fiber optic links. If you need to set parameters, please download the “Signalfire2” app to set it.



## OPM and Optical Modules

### Optical power parameter settings.

1. The user logs in to the "signalfire2" app and connects to the machine Bluetooth

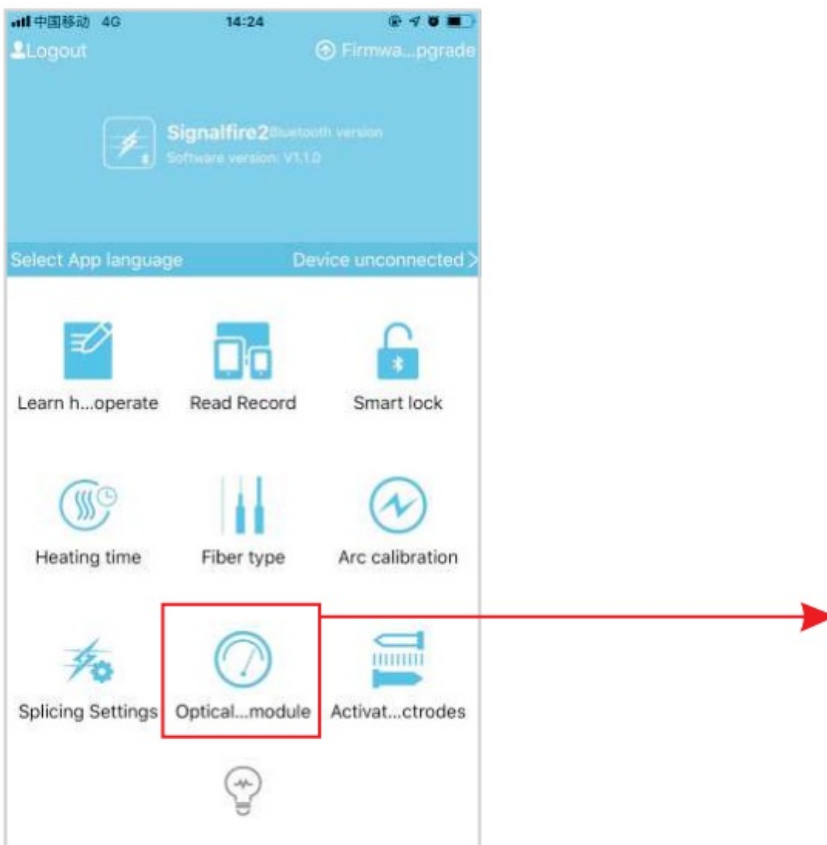

2. Turn on the power meter and light module, set and return,



## Chapter X Welcome Interface

New machine startup welcome interface: When a newly purchased fusion splicer starts up, the welcome interface will be displayed. After the user completes the fusion splicing of a single fiber, it will not be displayed again



## Welcome Interface



## Chapter XI Intelligent Management

Intelligent management: Intelligent management is used to set the working hours and usage objects of the

welding machine, making it convenient for administrators to effectively manage their own devices.

1. Bluetooth connection between mobile phone and welding machine

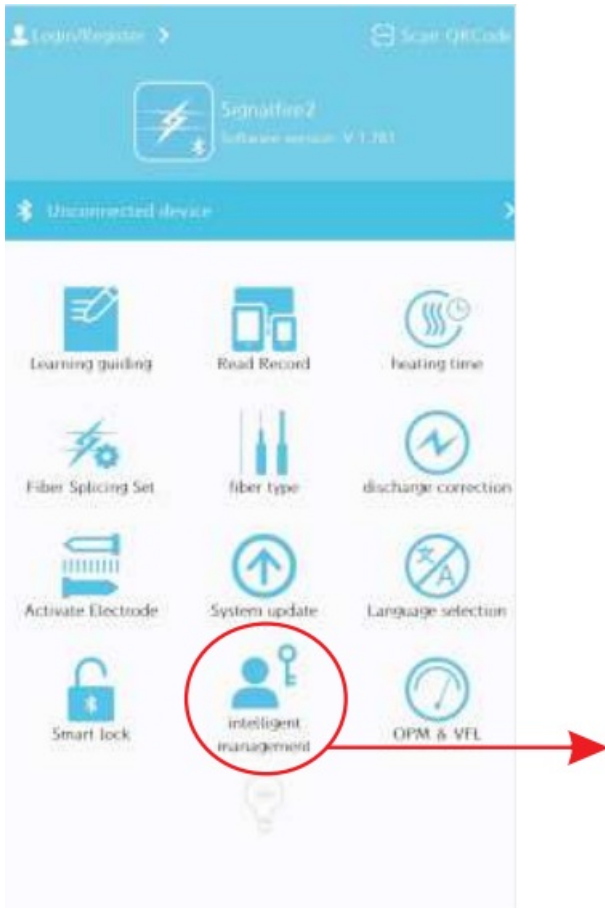

2. Click on Intelligent Management to view and manage your own welding machine.

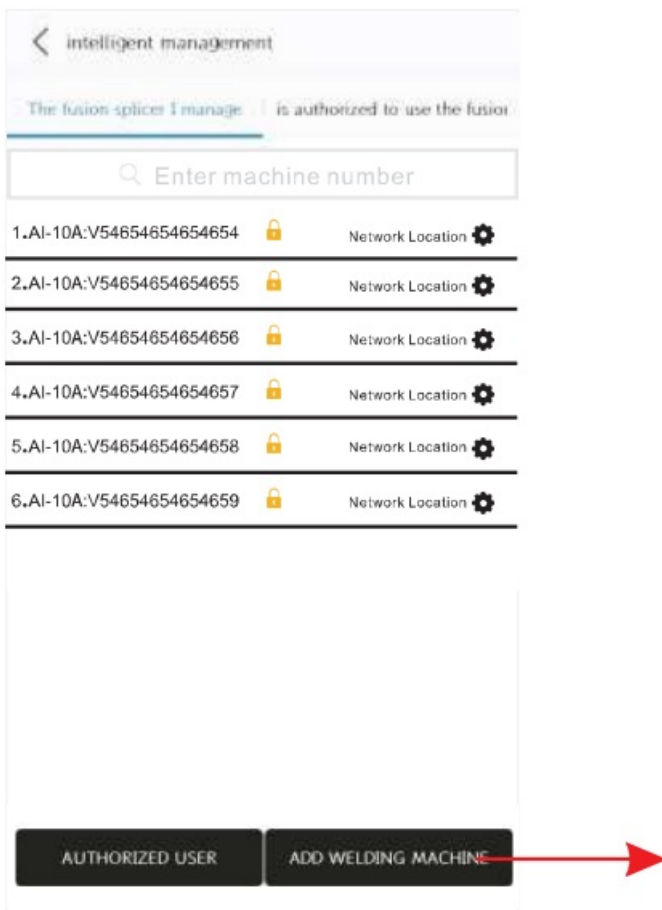

3. Click on Add Welding Machine to add the welding machine to be managed

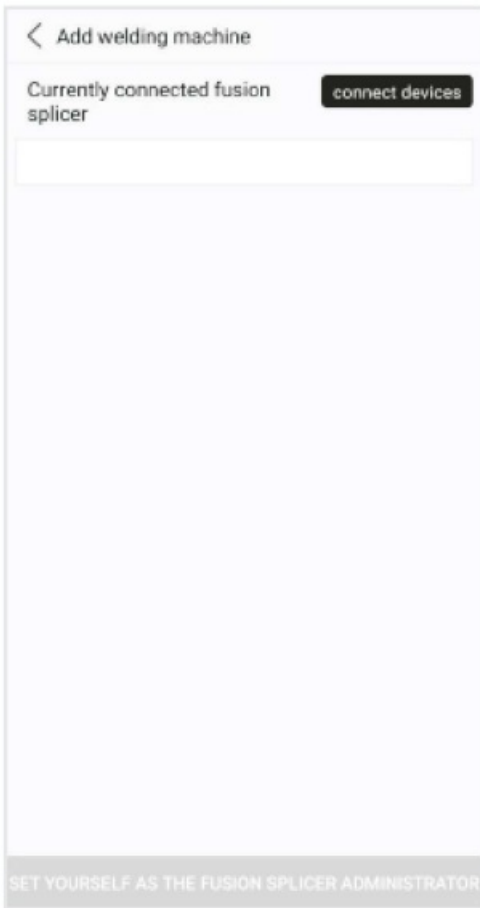

4. Click on the setting icon"" to personalize the welding machine



5. Click on the network location to view the addresses used by the welding machine online.



6. If you are authorized to use a welding machine, you can view the welding machines that you have been allowed to use by other welding machine administrators.





---

## Documents / Resources

	<p><a href="#">Signal Fire AI-10A Optical Fiber Fusion Splicer</a> [pdf] User Manual AI-10A Optical Fiber Fusion Splicer, AI-10A, Optical Fiber Fusion Splicer, Fiber Fusion Splicer, Fusion Splicer, Splicer</p>
---	---

## References

- [User Manual](#)